

UNIVERSAL MOTOR
FOR OFFICE EQUIPMENT

GUANGZHOU HAOQING MOTOR CO.,LTD

UC46-25B UNIVERSAL MOTOR



APPLICATION—

- Paper Shredder
- And so on

MECHANICAL DIMENSIONS

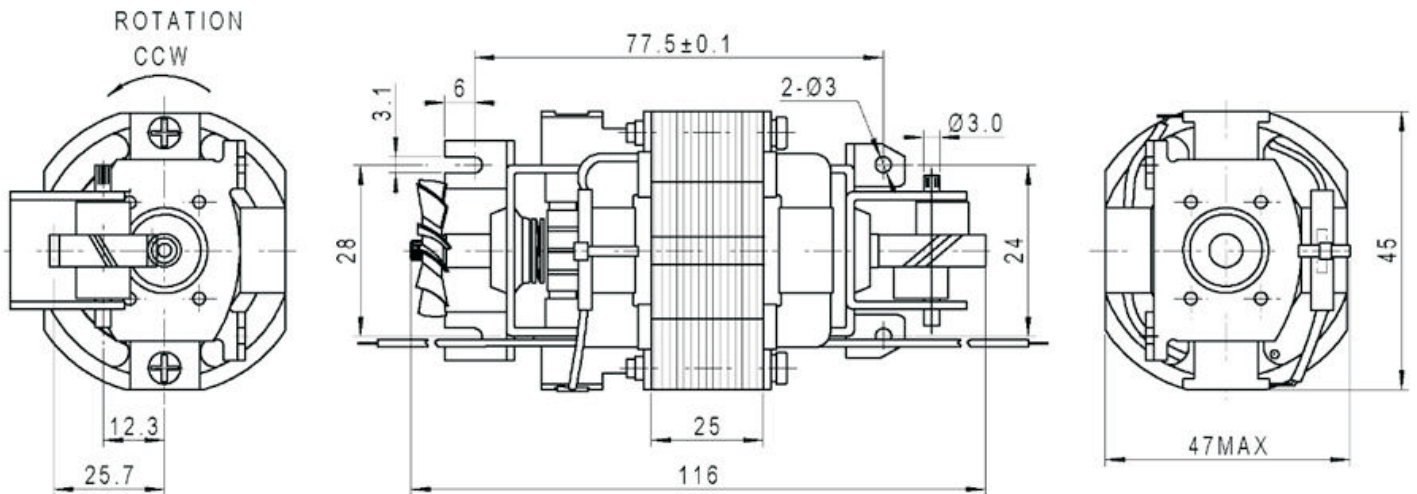

TECHNICAL DATA

Model	Voltage (V)	Frequency (Hz)	No-Load		On-Load					
			Speed (rpm)	Current (A)	Speed (rpm)	Torque (N.m)	Current (A)	Input power (W)	Output power (W)	Eff (%)
UC46-25B	120	60	21000	0.55	8968	0.043	1.004	121	40.5	33

Remark: We can produce according to customers requirement.

UC46-30B UNIVERSAL MOTOR



APPLICATION—

- Paper Shredder
- And so on

MECHANICAL DIMENSIONS

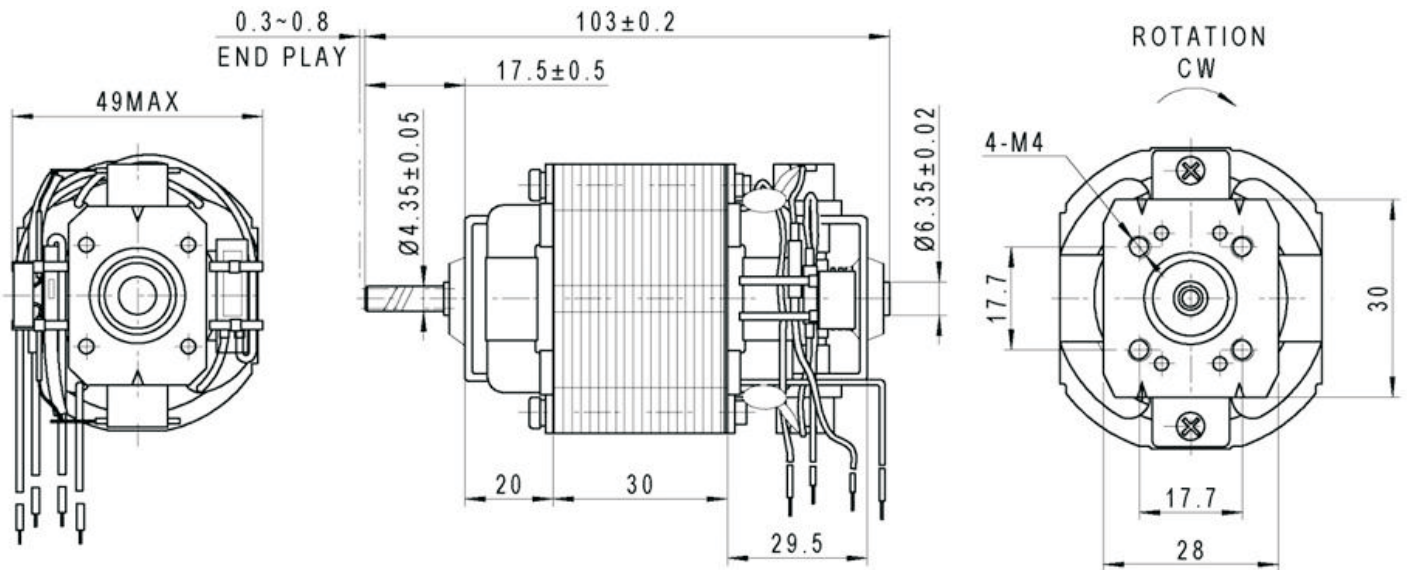

TECHNICAL DATA

Model	Voltage (V)	Frequency (Hz)	No-Load		On-Load					
			Speed (rpm)	Current (A)	Speed (rpm)	Torque (N.m)	Current (A)	Input power (W)	Output power (W)	Eff (%)
UC46-30B	230	50	16000	0.22	8968	0.043	1.004	121	40.5	33

Remark: We can produce according to customers requirement.

UC54-22B UNIVERSAL MOTOR

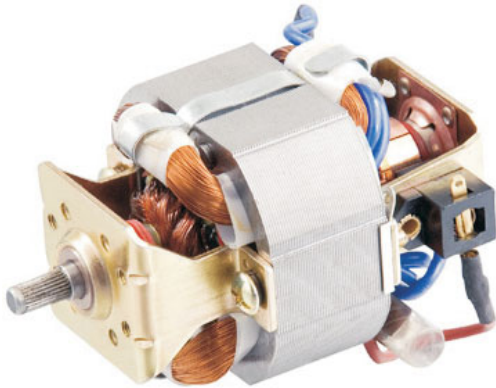

APPLICATION—

- Paper Shredder
- And so on

MECHANICAL DIMENSIONS

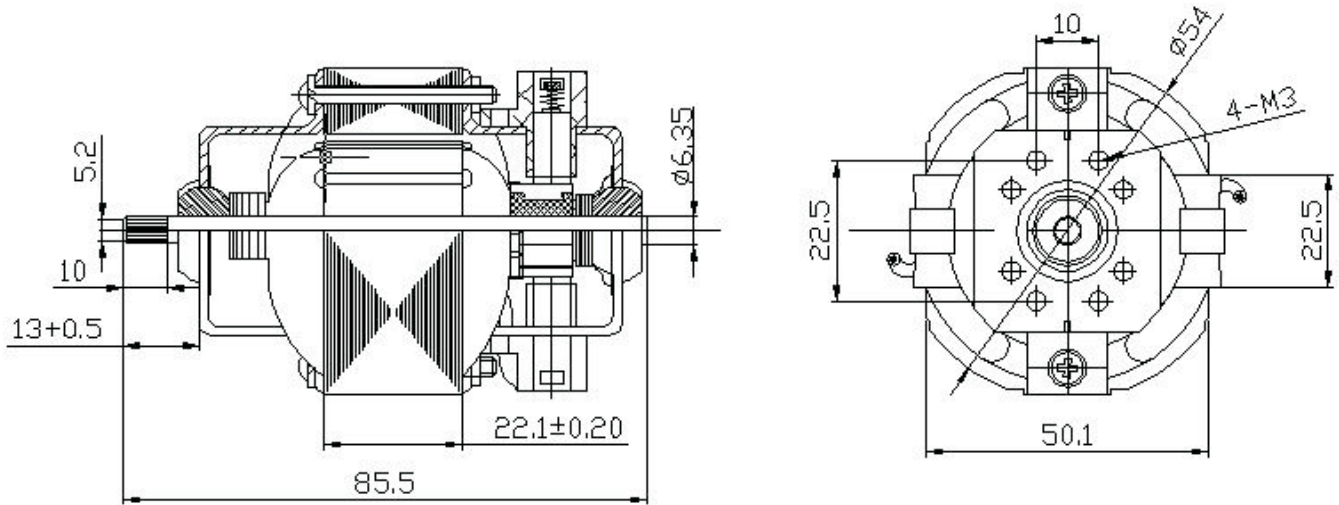

TECHNICAL DATA

Model	Voltage (V)	Frequency (Hz)	No-Load			On-Load			Input power (W)	Output power (W)	Eff (%)
			Speed (rpm)	Current (A)	Power (W)	Speed (rpm)	Torque (N.m)	Current (A)			
UC54-22B	220	50/60	23000	0.65	65	10000	0.07	1.75	180	92	51.2
UC54-22B	110	50/60	23000	0.3	65	10000	0.07	0.85	180	92	51.2

Remark: We can produce according to customers requirement.

UC54-40B UNIVERSAL MOTOR

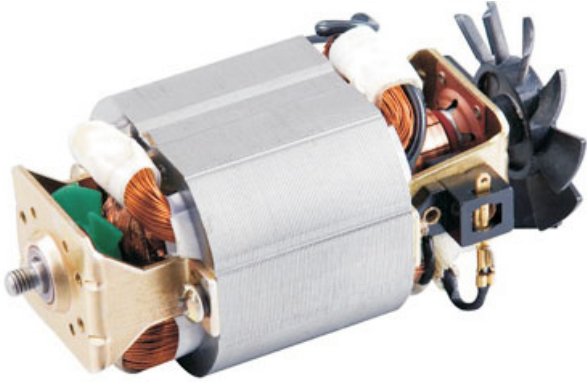

APPLICATION—

- Paper Shredder
- And so on

MECHANICAL DIMENSIONS

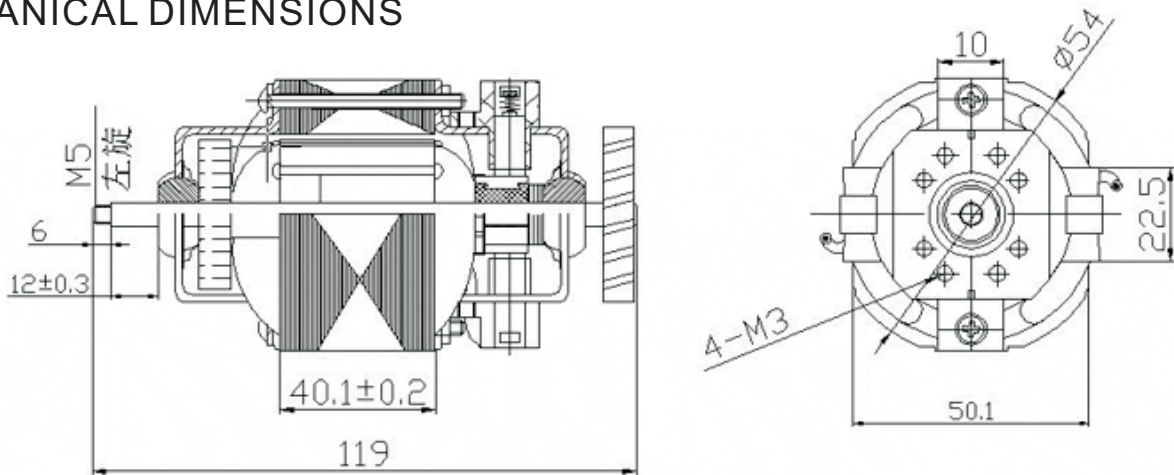

TECHNICAL DATA

Model	Voltage (V)	Frequency (Hz)	No-Load			On-Load			Input power (W)	Output power (W)	Eff (%)
			Speed (rpm)	Current (A)	Power (W)	Speed (rpm)	Torque (N.m)	Current (A)			
UC54-40B	220	50/60	23500	0.42	90	10600	0.115	1.08	247.6	127.5	51.2

Remark: We can produce according to customers requirement.

GUANGZHOU HAOQING MOTOR CO.,LTD

E-mail: sherry@gzhqmotor.com

Website: <http://www.gzhqmotor.com>